

**SELECTION
CARE
AND USE**

CRAFTSMAN®

Professional



PLANES

CRAFTSMAN TOOLS FOR EVERY JOB

This booklet illustrates a complete line of high quality planes. In addition, a large variety of other tools is available for every purpose.

You will find your job easier and more satisfying when you use the correct CRAFTSMAN fine tool.

KEEP THIS BOOKLET HANDY FOR FUTURE REFERENCE

The many suggestions on selection, care, and use of planes are based on the opinions of authorities in the woodworking field. We hope that you will find these hints helpful in your work.

**A GUIDE
TO
BETTER PLANING**

**With Suggestions For
"USING THE TOOL TO FIT THE JOB"**

Model numbers of all planes are stamped on the cutter.

For future reference when ordering parts we suggest that you encircle the model number of your plane on the parts list in the back of this book.

Copyright, 1951

SEARS, ROEBUCK AND CO.

CRAFTSMAN *Professional* PLANES

REG. U. S. PAT. OFF.

SUPER QUALITY



Tempered
"Super Tuff"
Steel Cutters

Craftsman Planes have been designed to give you satisfaction and long service. Make use of their many outstanding advantages by knowing your plane. You will be amply rewarded in giving it the care deserving of so fine a tool.

More and more master carpenters and men who know fine tools are choosing Craftsman Super-Quality Planes for more accurate, faster and smoother cutting. You, too, will be proud to own planes having all these fine features.

- **SUPER-TUFF VANADIUM CUTTER** — Scientifically heat-treated and oil tempered to hold a razor-like edge after honing. Large hole at end of slot so located that it is not necessary to slide cutter cap over the cutting edge of blade, thereby dulling it.
- **ADJUSTABLE, SNUG-FITTING FROG** with large accurate bearing surface for secure fastening to bed of plane. Eliminates jumping and side play.
- **CLAMP ASSEMBLY** prevents chatter by holding cutting iron firmly in place.
- **LARGE ADJUSTING NUT** — Brass Nickel Plated—and strong steel **LATERAL ADJUSTING LEVER** permit closest depth and sidewise adjustments.
- **HANDLE AND KNOB** of sensational new durable plastic which is many times stronger than wood. No warping or splitting. Ample room for easy, comfortable grip.
- **PLANE BED** of high quality gray iron, carefully machined, with finely ground and polished bottom and reinforced frame.

QUALITY PARTS MAKE QUALITY PLANES

CRAFTSMAN *Professional* PLANES

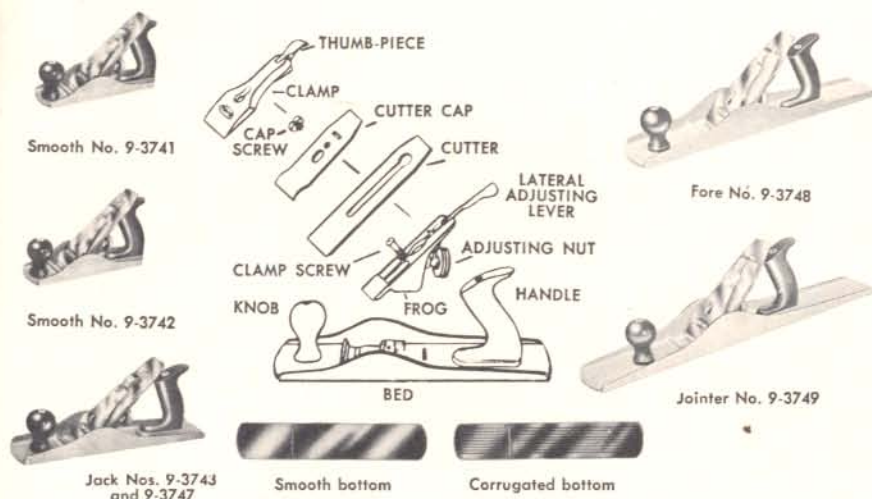

WHEN ORDERING PARTS SPECIFY MODEL NUMBERS AND PART NUMBERS LISTED ON PAGE 17

DUNLAP PLANES

LOW IN PRICE — HIGH IN QUALITY — WITH THESE PLUS FEATURES

CUTTER of Alloy Tool Steel, Tempered to hold an edge.
POSITIVE ADJUSTMENT with large brass Adjusting Nut and long, heavy Lateral Adjusting Lever.
BED & FROG of heavy gray iron, precision machined at points of contact. Bed ground smooth and reinforced.

LONG BEARING CAP with bottom edge accurately ground along blade edge.
SPRING CLAMP assuring firm seating to cutter, eliminating chatter.
HANDLE & KNOBS hardwood, mahogany finish. Comfortable clearance between Handle and Frog.

ALL CRAFTSMAN AND DUNLAP PLANES

FULLY GUARANTEED against defects in any particular. Satisfaction assured.

**A CRAFTSMAN PROFESSIONAL PLANE
FOR EVERY PURPOSE**

TYPES OF PLANES

BENCH PLANES

SMOOTH

Cat. No. 9-3741 (Model 619.3741) CRAFTSMAN—Smooth Bottom, 8" long, 1-3/4" Cutter.

Cat. No. 9-3742 (Model 619.3742) CRAFTSMAN—Smooth Bottom, 9" long, 2" Cutter.

Cat. No. 9-3726 (Model 619.3726) DUNLAP—Smooth Bottom, 8" long, 1-3/4" Cutter.

Cat. No. 9-3738 (Model 619.3738) DUNLAP—Smooth Bottom, 9" long, 2" Cutter.



Smooth Plane

A plane from 7" to 12" long is known as a SMOOTH PLANE. Its main adaptation is for finishing off an uneven surface. Because of its small size it will find its way into minor depressions of the wood, making the surface smooth. Results may not be as fine or flat as those obtained from using a larger plane, such as the Jointer, but the surface becomes smooth without the removal of an excessive amount of material.

JACK

Cat. No. 9-3743 (Model 619.3743) CRAFTSMAN—Smooth Bottom, 14" long, 2" Cutter.

Cat. No. 9-3747 (Model 619.3747) CRAFTSMAN—Corrugated Bottom, 14" long, 2" Cutter.

Cat. No. 9-3739 (Model 619.3739) DUNLAP—Smooth Bottom, 14" long, 2" Cutter.



Jack Plane

A plane 14" or 15" long is called a JACK PLANE. It is considered *the* plane to use on rough surfaces where a coarse chip is desired. It can be used, also, to obtain a relatively smooth, flat surface. Its length and weight make it a powerful tool, and it may be used to true up the edge of a board after sawing.

USE THE TOOL DESIGNED FOR THE JOB

FORE

Cat. No. 9-3748 (Model 619.3748) CRAFTSMAN—Corrugated Bottom, 18" long, 2-3/8" Cutter.

A plane 18" long is a FORE PLANE, generally used for fine flat finishing. Because it is shorter than the Jointer Plane it is easier to handle, especially for the journeyman carpenter. Sometimes it is used as either a Jack Plane or a Jointer Plane by experienced workmen.



Fore Plane

JOINTER

Cat. No. 9-3749 (Model 619.3749) CRAFTSMAN—Corrugated Bottom, 22" long, 2-3/8" Cutter.

A JOINTER PLANE is 20" to 30" long. The most commonly used size, however, is 22". Its great length and weight reduce chatter and keep the cutter from tearing the wood. With the cutter set fine it is the plane for obtaining the smoothest and flattest finishes. It will take down, better than any other type of plane, two wood surfaces that are to be brought together to form a close-fitting joint.



Jointer Plane

ADJUSTMENTS

All of the Bench Planes discussed above are equipped with the same types of adjustments. Cutters are extended or retracted by turning the adjusting nut until the proper projection of the cutter through the mouth in the bottom of the plane is obtained. Lateral adjustment is controlled by the lateral adjustment lever located just above the grip or handle of the plane. The cutter is held in position by pressure from the clamp which fits over it. (See diagram on page 11).

SEE PAGE 11 FOR INSTRUCTIONS ON RE-ASSEMBLY

RABBET AND FILLISTER PLANE

Cat. No. 9-3730 (Model 619.3730) CRAFTSMAN—8" long, 1-1/2" Cutter.



No. 9-3730

The Rabbet & Fillister Plane is specially designed for planing grooves or rabbets on the edges of a board. It has a width gauge and a depth gauge as well as a spur which scores the wood in advance of the cutter blade. The spur prevents tearing of the surrounding wood not being removed by the operation. There are two cutter seats. When the cutter is placed in the forward seat, the plane can be used as a bull-nose Rabbet Plane. The adjustable arm and fence can be placed on either side of the plane, making a right or left hand fillister. Sides are ground and polished.

COMBINATION PLANE

Cat. No. 9-3728 (Model 619.3728) CRAFTSMAN

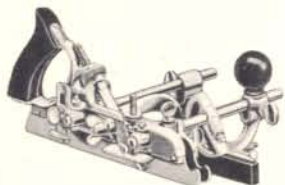

No. 9-3728

This takes the place of several planes and is adjustable for right or left hand. A variety of adjustments and attachments makes it the tool for dadoing, rabbeting, tonguing and grooving, beading, slitting, sash cutting, planing and routing. Twenty-three steel cutters are included with this plane. Handle, knob, and fence are of hardwood.

COMPLETE INSTRUCTIONS PACKED WITH EACH PLANE

BLOCK PLANES

A Block Plane is designed to cut the end grain of a piece of wood. The cutter rests at an angle of approximately 20 degrees to the surface being planed, except CRAFTSMAN Plane No. 9-3732 which has a 12 degree setting. This is a lower angle than that of a Bench Plane cutter and permits the shearing action necessary for cutting off the end grain.

Cat. No. 9-3700 (Model 619.3700)—Smooth Bottom, 7" long, 1-5/8" Cutter.



No. 9-3700

A low-priced plane of good quality. Bottom ground smooth. Adjusted by loosening adjusting screw until a slight tap on the side or top of cutter causes cutter to move to the desired position. Turn adjusting screw clockwise to tighten.



Dunlap
No. 9-3701

Cat. No. 9-3701 (Model 619.3701)—DUNLAP. Smooth Bottom—7" long, 1-5/8" Cutter.

Good quality. Bottom and sides ground smooth. Easy adjustment. A turn of adjusting screw extends or retracts cutter. For sidewise adjustment or removal of cutter release wedge-like lever on clamp.

Cat. No. 9-3704 (Model 619.3704) CRAFTSMAN—Smooth Bottom—6" long, 1-5/8" Cutter.

A high quality plane with "Super Tuff" steel cutter. Bottom and sides ground and polished smooth. Instant cutter adjustment: cutter extended or retracted by turning adjusting screw; lateral adjustment by moving lever on cutter. Mouth opening adjustable by merely loosening knob nut at front of plane and turning metal cam at the base of knob nut.



Craftsman
No. 9-3704



Cat. No. 9-3732 (Model 619.3732) CRAFTSMAN—Knuckle Joint Plane—Smooth Bottom, 7" long, 1-5/8" Cutter.



Craftsman
No. 9-3732

A top quality plane especially suited to cross grain planing. "Super-Tuff" steel cutter set at low 12° angle. Bottom and sides ground and polished. Jointed cap snaps into position and holds cutter firmly. Turn of adjusting screw extends or retracts cutter. Mouth adjustment same as on Plane 9-3704 described above.

KNOW HOW TO USE YOUR PLANE

PLANING THE SURFACE (Use Bench Plane For Best Results)

EXAMINE THE BOARD

Sight across the best surface of the board and mark off any high corners. Determine the direction of the grain on the surface and along the edge.

HOLD BOARD SECURELY

Butt one end of the board against a bench stop, or clamp the board securely in a vise, with the grain running in the direction in which you will be planing.

ADJUST CUTTER

Extend for thick shaving, retract for fine.

PLANE WITH GRAIN



FIG. 1

To obtain a smooth surface, the plane must be pushed with the grain. (Fig. 1)

USE PROPER PRESSURE

At the beginning of your stroke put pressure on the knob of the plane; at the end, bear down on the handle. (Fig 2). Check surface with a straight edge. To remove high places adjust cutter for very fine shaving.



FIG. 2

PLANING THE EDGE (Use Bench Plane for Best Results)



FIG. 3

Clamp board in a vise. Place thumb in back of knob of plane and allow the fingers to slide along the surface of the board, guiding the plane straight along the edge. Hold handle firmly with other hand. Take full strokes and cut full width (Fig. 3). Alternate pressure on knob and handle as in planing the surface. Check edge with a try-square. Make fine shavings in removing high places.

PLANING THE END (Use Block Plane For Best Results)

Clamp board securely in vise. Hold plane in same manner as for planing edge, but at an angle with the side of the board so as to obtain a shearing action. Plane half-way from each end (Fig. 4). Otherwise the corners will break off.



FIG. 4

PLANE THE WAY THE EXPERTS DO

USING THE RABBET PLANE

1. Adjust the cutter to cut shavings of the proper thickness as in ordinary planing. Be sure cutter is exactly in line with the side of the plane and projects evenly through the bottom.

2. Adjust spur, which is the round cutter fastened to the side of the plane, by loosening the center screw and turning spur clock-wise until the fourth notch engages the pin. Re-tighten center screw. Keep spur in closed position when plane is not in use.



CUTTING A RABBET WITH A RABBET PLANE

3. Experimenting and practice will determine how to set the width and depth gauges.

4. If the gauges cannot be used because board being rabbeted is too thin, wide, or narrow, a strip of wood may be nailed or clamped to the board as a width gauge. The depth, in the case of a thin board, should be located along edge by using a marking gauge or pencil line.

5. Have board held firmly on bench. Hold plane level, and press so that width gauge is against edge of board.

6. Take each stroke evenly and for entire length of board. The spur scores the wood, minimizing any effects the grain of the wood might have in causing the cut to become uneven in width. Continue until depth gauge is against the upper surface of board.

7. For best results keep cutter and spur sharp.

8. A light coating of oil on the bright parts of the plane will preserve the accuracy of the ground surfaces.

USING THE COMBINATION PLANE



The CRAFTSMAN combination Plane (No. 9-3728) provides the amateur cabinet maker with the means of producing decorative effects that give his work the "professional touch". Mechanics find it valuable for beading—either on the edge or on the center of the board—plowing, dadoing, rabbeting, matching, slitting, and sashwork.

CUTTING A RABBET WITH A COMBINATION OR UNIVERSAL PLANE

COMPLETE INSTRUCTIONS, INCLUDING DIRECTIONS FOR OBTAINING PARTS, ARE PACKED WITH EACH PLANE.

THE IMPORTANCE OF TAKING CARE OF YOUR PLANES

The plane, like any other tool, will do its best work when given proper care. Keep the cutter sharp and keep it bevelled and adjusted properly. Protect the cutter when it is not in use. Know how to disassemble and re-assemble your planes correctly.

The time you spend caring for these tools will be more than compensated for by the time you *save* through increased efficiency.

The following section of this booklet is devoted to the proper maintenance of your planes. So that you will get the greatest pleasure and satisfaction from your own woodworking, we suggest that you read these pages carefully.

TAKING YOUR PLANE APART — SHARPENING THE CUTTER RE-ASSEMBLY

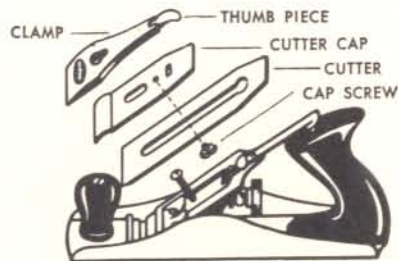

FIG. 5

Now is the time to get acquainted with your Bench Plane. One of the first things to remember is that good results and ease in operation depend upon the proper condition and correct adjustment of the tool.

Use the accompanying picture diagram (Fig. 5) to learn the names and locations of the various parts; refer to it while following instructions. The cutter is also known as the "plane iron" or "plane blade".

A plane is taken apart to sharpen the cutter or to change the position of the cutter cap in relation to the cutting edge of the blade.

To take the plane apart, lift up the thumb piece of the clamp. Remove clamp and then the cutter cap and cutter which are held together by a large-headed screw known as the cap screw.

Using the clamp as a screw driver, loosen the cap screw and slide the cutter cap in slot until the head of the cap screw passes through the enlarged hole at the end of the slot. You now have three parts of your plane taken apart: the clamp, the cutter cap, and the cutter.

One of the features of a CRAFTSMAN or DUNLAP cutter is that the enlarged hole at the end of the slot is so located that it is not necessary to slide the cutter cap over the cutting edge of the blade. This protects the edge and minimizes the danger of cutting the fingers.

SHARPENING THE CUTTER BLADE

Since the cutter has not been hand-honed on a whetstone in the factory, we suggest that, for top performance, this be done before you use the plane.

In many cases frequent sharpening on an oilstone, as later described, is all that is necessary to keep a cutter blade sharp. If the cutting edge of the cutter reflects light it needs sharpening. *Never attempt to work your plane if the cutter is the least bit dull.*

The following steps are necessary if the cutter is extremely dull or has become nicked:

1. Remove the nicks and straighten the cutting edge of the cutter by carefully placing it against a revolving grinding wheel (Fig. 6). Slide the cutter from right to left across the wheel. Resulting edge must be square with the edge of the side of the cutter (Fig. 7).

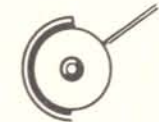

FIG. 6

2. Hold the cutter, with the bevel side down, firmly between the thumb and index (fore) finger of each hand. Place cutter on the tool rest of grinding wheel so that the existing bevel of the blade coincides with the curve of the grinding wheel (Fig. 8).

NOTE: The correct bevel angle is 25 degrees. This makes the bevel a little longer than twice the thickness of the cutter blade.



FIG. 8

3. When the proper location of the cutter on the rest has been determined, bring the cutter gradually but firmly down on the revolving wheel. Slide the cutter back and forth from right to left (Fig. 9).

CAUTION: Pressure should not be so great as to cause cutter to overheat and turn blue. Dip the cutter frequently in water to prevent overheating.



FIG. 7



FIG. 9

Using the index finger as a gauge against the tool rest—and not changing its position on the cutter when dipping in water—insures obtaining the same bevel on the cutter while sharpening on the grinding wheel (Fig. 10).

4. Continue grinding, as in step 3, until a wire edge or burr appears across the entire width of the cutter. This so-called wire edge is an extremely thin piece of excess metal which is removed by whetting on a flat oilstone.

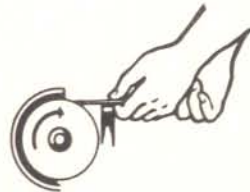

FIG. 10

WHETTING

It is not always necessary to use the grinding wheel to restore sharpness to a cutter. Careful whetting on an oilstone at frequent intervals will keep the cutter in tip-top cutting condition. When whetting be careful that the bevel is not rounded.

1. Clean off the surface of the oilstone and place a few drops of oil on it as a lubricant. This oil will also float the small particles of steel resulting from whetting and will prevent their clogging the stone.

2. Place the bevel of the cutter on the stone with the back edge raised until the bevel lies flat on the oilstone (Fig. 11).

3. Move the cutter back and forth on the stone, taking care to move hands PARALLEL with the surface of the stone. The angle between the cutter and stone MUST remain the same throughout each stroke (Fig. 12).



FIG. 11



FIG. 12

For greater accuracy and ease use the CRAFTSMAN Blade and Chisel Sharpening Guide No. 9-3774 (Fig. 13). This guide holds the cutter securely so that it can be sharpened or honed to the correct bevel or angle. Adjustable vertical support at heel of guide maintains the desired angle to oilstone. A roller at the base



FIG. 13

Craftsman Blade Sharpening Guide No. 9-3774

of this support allows for free back and forth movement of guide.

ADJUST YOUR PLANE TO MEET THE CONDITION



FIG. 14

4. Remove the wire edge by taking a few strokes with the flat side of the cutter held **FLAT** on the oilstone. Do not make any bevel on this side (Fig. 14).

5. Finishing with a few strokes on a leather strop gives a keener edge.

ASSEMBLY AND ADJUSTMENT OF PLANE

1. Hold cutter of the bench plane in left hand with bevel down.*

2. Place cutter cap on cutter so that head of cap screw goes through enlarged hole at end of slot on cutter. This is best done by holding cutter cap at right angle to cutter (Fig. 15).



FIG. 15

3. Turn the cutter cap until it is parallel to the cutter, sliding it towards the cutting edge of the cutter until the edge of the cutter cap is about 1/16 inch from the cutting or sharpened edge of the blade (Fig. 16). This is the best measurement for ordinary work.



FIG. 16

4. For very fine work, and for planing burly or cross-grained wood, the distance from the cutting edge of the cutter to the edge of the cap should be reduced to about 1/64 of an inch.

5. Tighten cutter cap screw with a screwdriver or clamp. Be sure adjustment just completed does not change and that the cap screw is really tight so that shavings will not enter between cutter and blade cap.

6. Place assembled unit, with bevelled side of cutter down,* on the frog of the plane. Be sure slot in cutter cap is placed over end of fork (for adjustment) and that lower end of lateral adjustment lever is in the slot of the cutter (Fig. 17).

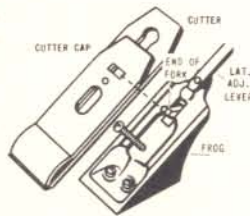

FIG. 17

*NOTE: The Cutter of a *Block Plane* is always put into position with the bevel side *up*.

USE THE RIGHT PLANE, USE IT CORRECTLY, GIVE IT CARE

7. With thumb piece of clamp up, place clamp in position, allowing the cap to slide under the head of the cap screw on the frog. The narrow part of the pear-shaped hole in the clamp should now be under the head of the cap screw (Fig. 18).



FIG. 18

8. Tighten clamp by pressing down on clamp handle until it snaps into position in line with top of clamp. This should be done with firm pressure. Do not force. If impossible to close thumb piece, the assembly of the cutter and cutter cap may not be in proper position on the frog, or the clamp screw on the frog may be too tight. It should not work loosely, either, as plane would get out of adjustment easily while in use.



FIG. 19

9. Hold the plane upside down with the bottom level with the eye and knob toward face. While it is in this position, turn the knurled adjusting nut either to the right or left to feed the cutter in or out (Fig. 19). Also, move the lateral adjusting lever to the right or left until the cutting edge of the cutter is parallel to the bottom of the plane (Fig. 20). This may seem awkward at first but it is the only practical method of correctly adjusting the cutter assembly.



10. A few practice strokes on a piece of wood will quickly determine if cutter is properly adjusted. Best results will be obtained and plane will be easier to work if you do not try to make a heavy shaving.

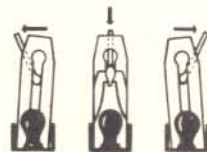

FIG. 20

NOTE: Frog should not be adjusted. This is done at the factory.

PROTECT THE CUTTER

When not in use, the plane should lie on its side so that there is no pressure on the cutter blade.

HOW TO ORDER REPAIR PARTS

All parts shown on the following lists and illustrated on the parts diagrams may be ordered through any Sears retail or mail order store. Selling prices will be furnished on request when you order parts by mail from the mail order store which serves the territory in which you live, or parts will be shipped at prevailing prices and you will be billed accordingly.

WHEN ORDERING REPAIR PARTS ALWAYS GIVE THE FOLLOWING INFORMATION:

1. The Part Number in this List.
2. The Part Name in this List.
3. The Model Number of your Plane.

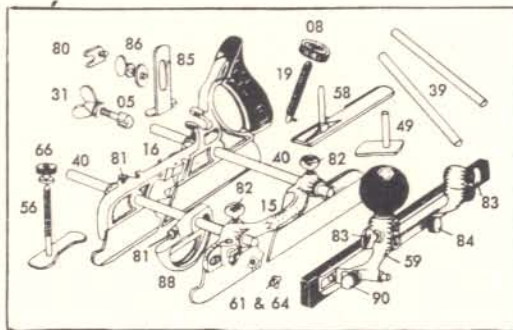

PARTS FOR CRAFTSMAN COMBINATION PLANE
MODEL 619.3728

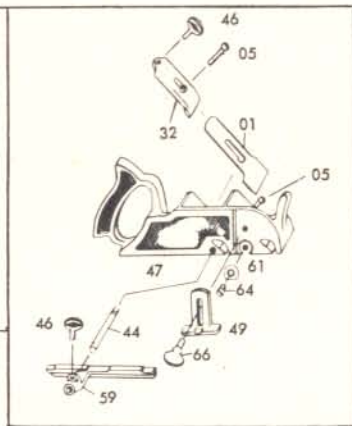

PARTS FOR CRAFTSMAN RABBET
& FILLISTER PLANE
MODEL 619.3730

PART NO.	PART NAME
3728-96	Set of 23 Standard Cutters Boxed (Not shown above)
3728-05	Cutter Bolt
3728-08	Adjusting Nut
3728-15	Movable Bed
3728-16	Bed Assy. (With Wood Handle)
3728-19	Adjusting Screw (With Pin)
3728-31	Cutter Bolt Wing Nut
3728-39	Short Rods
3728-40	Long Rod
3728-49	Depth Gauge
3728-56	Adjustable Depth Gauge
3728-58	Adjustable Guide Plate
3728-59	Fence
3728-61	Spur
3728-64	Spur Screw
3728-66	Depth Gauge Thumb Nut
3728-80	Cutter Bolt Clip and Screw
3728-81	Arm Set Screw
3728-82	Movable Bed Thumb Screw
3728-83	Fence Thumb Screw
3728-84	Fence Adjusting Screw
3728-85	Slitting Cutter Stop
3728-86	Slitting Cutter Thumb Screw
3728-88	Cam Rest
3728-90	Fence Arm Set Screw

PART NO.	PART NAME
3730-01	Cutter
3730-05	Clamp Screw
3730-32	Clamp
3730-44	Rod
3730-46	Clamp & Fence Thumb Screw
3730-47	Bed Assembly
3730-49	Depth Gauge
3730-59	Fence
3730-61	Spur Cutter
3730-64	Spur Cutter Screw
3730-66	Depth Gauge Thumb Screw

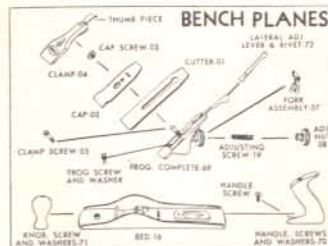

PARTS FOR BENCH PLANES

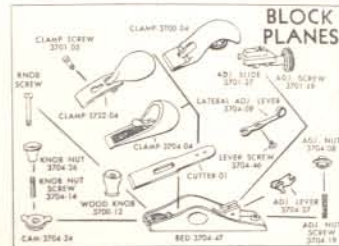

PARTS FOR BLOCK PLANES

Part Name	PARTS FOR BLOCK PLANES			
	Model 619.3700 Part Number	Model 619.3701 Part Number	Model 619.3704 Part Number	Model 619.3732 Part Number
Cutter*	3700-01	3701-01	3704-01	3701-01
Clamp	3700-04	3704-04	3704-04	3732-04
Adjusting Nut	None	None	3704-08	None
Lateral Adjusting Lever	None	None	3704-09	None
Lever Screw	None	None	3704-46	None
Cam	None	None	3704-24	3704-24
Knob Nut	None	None	3704-26	3704-26
Clamp Screw	None	3701-05	3701-05	3701-05
Knob Nut Screw	None	None	3704-14	3704-14
Adjusting Lever	None	None	3704-37	None
Adjusting Slide	None	3701-27	None	3701-27
Adjusting Screw	None	3701-19	None	3701-19
Adjusting Nut Screw	None	None	3704-19	None
Bed	3700-47	3701-16	3704-47	3732-47
Knob Screw	F.H.S.M.S.	# 10-24x1 F.H.S.M.S.	None	None
Wood Knob	3700-12	3701-12	None	None

PARTS FOR BENCH PLANES

Part Name	Model 619.3726 Part No.	Model 619.3738 Part No.	Model 619.3739 Part No.	Model 619.3741 Part No.	Model 619.3742 Part No.	Model 619.3743 Part No.	Model 619.3747 Part No.	Model 619.3748 Part No.	Model 619.3749 Part No.
	Cutter*	3711-01	3713-01	3713-01	3711-01	3713-01	3713-01	3713-01	3715-01
Cap	3741-02	3742-02	3742-02	3741-02	3742-02	3742-02	3742-02	3748-02	3748-02
Cap Screw	3741-03	3741-03	3741-03	3741-03	3741-03	3741-03	3741-03	3741-03	3741-03
Cutter, Cap & Screw Assembly*	3712-20	3714-20	3714-20	3712-20	3714-20	3714-20	3714-20	3716-20	3716-20
Clamp	3726-04	3738-04	3738-04	3741-04	3742-04	3742-04	3742-04	3748-04	3748-04
Frog, Complete	3726-69	3738-69	3738-69	3741-69	3742-69	3742-69	3742-69	3748-69	3748-69
Handle Screws & Washers	3726-70	3726-70	3739-70	3741-70	3741-70	3743-70	3743-70	3743-70	3743-70
Knob, Screws & Washers	3726-71	3726-71	3739-71	3741-71	3741-71	3743-71	3743-71	3743-71	3743-71
Adjusting Nut	3741-08	3741-08	3741-08	3741-08	3741-08	3741-08	3741-08	3741-08	3741-08
Adjusting Screw	3741-19	3741-19	3741-19	3741-19	3741-19	3741-19	3741-19	3741-19	3741-19
Fork Assembly	3741-07	3741-07	3741-07	3741-07	3741-07	3741-07	3741-07	3741-07	3741-07
Clamp Screw	3741-05	3741-05	3741-05	3741-05	3741-05	3741-05	3741-05	3741-05	3741-05
Lateral Adj. Lever & Rivet	3741-72	3741-72	3741-72	3741-72	3741-72	3741-72	3741-72	3741-72	3741-72
Frog Screw	Two # 12-24x5/8 Fillister Head Screws Per Plane								
Frog Screw Washer	Two Standard 1/4" Steel Washers Per Plane								
Handle Screw	None	None	# 12-24 x 5/8	None	None	# 12-24x5/8			
Bed	3726-16	3738-16	3739-16	3741-16	3742-16	3743-16	3747-16	3748-16	3749-16

*These parts may be purchased at Sears mail order or retail stores.

†Wood and plastic replacement knobs and handles are available.

NOTE: Wood and plastic knobs and handles are not interchangeable.